

# HIGH VOLTAGE N CHANNEL JFET

2N5277  
2N5278  
TN5277  
TN5278

## GEOMETRY 1143

- High BV<sub>DGO</sub> 300V - Selections to 400V.
- High Transconductance - to 6mmho

### MAXIMUM RATINGS

PARAMETER	2N5277 2N5278	TN5277 TN5278	UNITS
Gate Source Voltage	150	150	V
Gate Drain Voltage	200	150	V
Drain Source Voltage		150	V
Gate Current	10	10	mA
Device Dissipation <25°C	0.8	1	W
Linear Derating Factor	4.57	5.71	mW/°C
Storage Range	-55° to 20°C	-65° to +200°C	

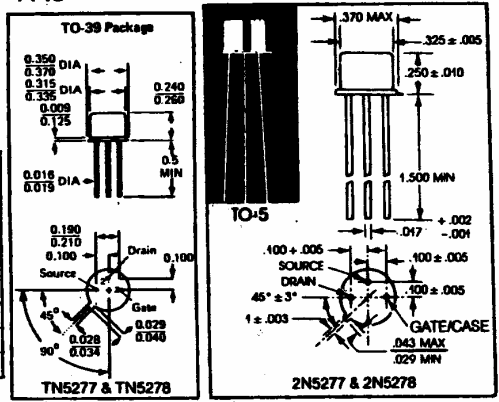

### ELECTRICAL CHARACTERISTICS AT 25°C FREE-AIR TEMPERATURE

PARAMETER	SYMBOL	TEST CONDITION	2N5277		2N5278		TN5277		TN5278		UNIT
			MIN.	MAX.	MIN.	MAX.	MIN.	MAX.	MIN.	MAX.	
Gate Reverse Current	IGSS	V <sub>GS</sub> = -75V, V <sub>DS</sub> = 0		5		5		5		5	nA
		V <sub>GS</sub> = -75V, V <sub>DS</sub> = 0, T <sub>A</sub> = 150°C		5		5		5		5	μA
Gate Source Breakdown Voltage	BV <sub>GSS</sub>	I <sub>G</sub> = 1.0μA, V <sub>DS</sub> = 0	150		150						V
Gate Source Breakdown Voltage	BV <sub>GSO</sub>	V <sub>DS</sub> = 0, I <sub>G</sub> = 11μA					150		150		V
Drain Gate Breakdown Voltage	BV <sub>DGO</sub>	I <sub>G</sub> = -1μA, I <sub>S</sub> = 0 (see note)					300		300		V
Saturation Drain Current*	I <sub>DSS</sub>	V <sub>DS</sub> = 30V, V <sub>GS</sub> = 0	2.5	12.5	10	25	2.5	12.5	10	25	mA
Gate Source Cutoff Voltage	V <sub>GS (off)</sub>	V <sub>DS</sub> = 30V, I <sub>D</sub> = 10nA	.5	7	2	10	.5	7	2	10	V
Forward Transconductance	g <sub>fs</sub>	V <sub>DS</sub> = 30V, V <sub>GS</sub> = 0, f = 1KHz	2	5	3	6	2	5	3	6	mmho
Output Conductance	g <sub>os</sub>	V <sub>DS</sub> = 30V, V <sub>GS</sub> = 0, f = 1KHz		25		60		25		.60	μmho
Input Capacitance	C <sub>iss</sub>	V <sub>DS</sub> = 30V, V <sub>GS</sub> = 0, f = 1MHz		25		25		30		30	pF
Feedback Capacitance	C <sub>rss</sub>	V <sub>DS</sub> = 30V, V <sub>GS</sub> = 0, f = 1MHz		5		5		5		5	pF
NOISE FIGURE	NF	V <sub>DS</sub> = 30V, V <sub>GS</sub> = 0V, f = 1KHz, BW = 200Hz, R <sub>G</sub> = 1MΩ		3		3		3		3	dB

\*Pulse test required, pulse width 300μs; duty cycle <3%  
Note - Special selection available up to 400 V

CRYSTALONCS  
2805 Veterans Highway,  
Suite 14  
Ronkonkoma, N.Y. 11779